

### 320 - GR ATENA

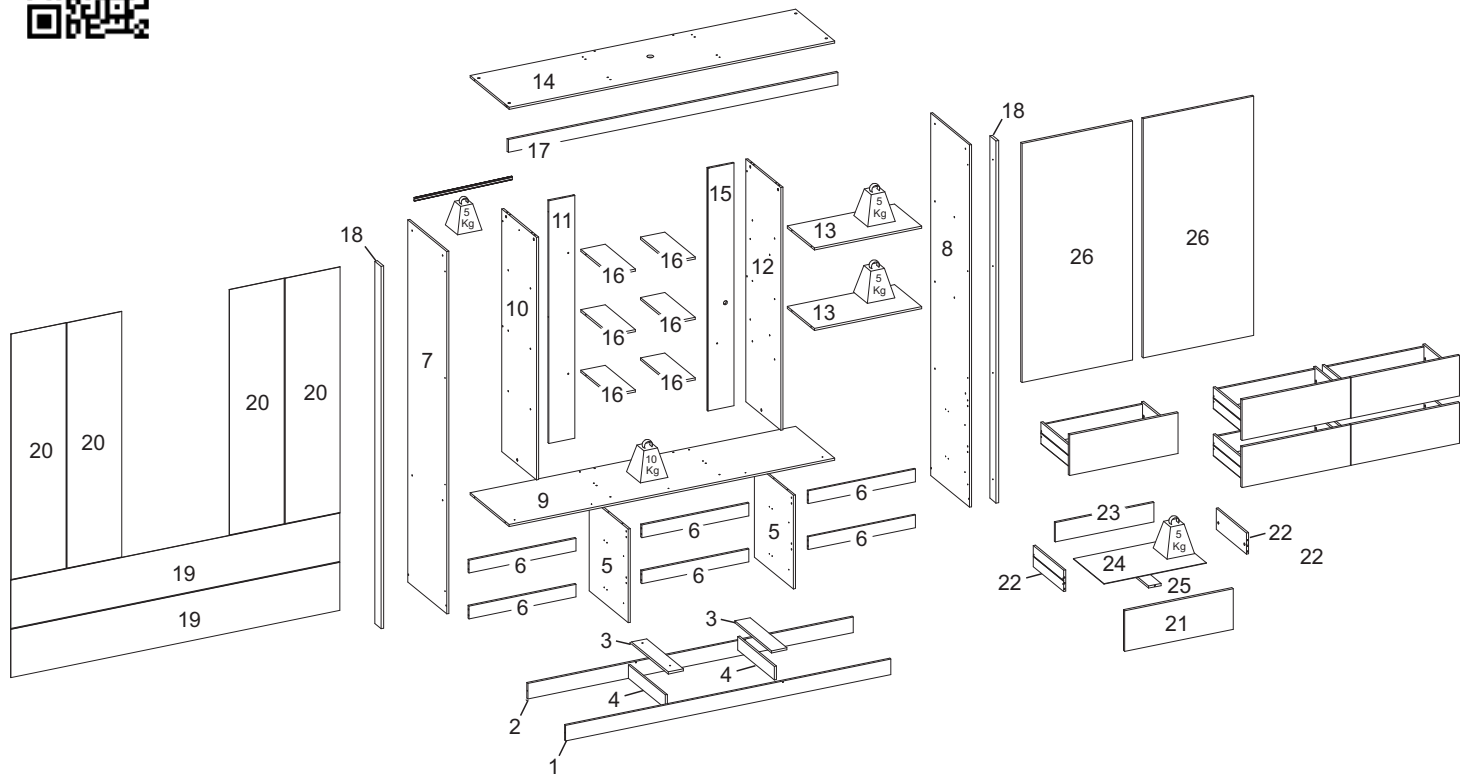

SEQ.	REF.	DESCRIÇÃO	DESCRIPTION	DESCRIPCIÓN	MAT.PRIMA	COMP.	LARG.	ESP.	QTD.
1	332887	Rodapé frontal	Front footer	Pie de página frontal	MDP	1878	88	12	1
2	332888	Rodapé traseiro	Back footer	Pie de página posterior	MDP	1878	88	12	1
3	332889	Trava divisória	Footer lock	Bloqueo de pie de página	MDP	424	88	12	2
4	332890	Trava rodapé	Footer lock	Bloqueo de pie de página	MDP	424	76	12	2
5	332891	Divisória inferior	Lower partition	Divisor inferior	MDP	530	449	12	2
6	332892	Vista gaveta	Drawer view	Vista del cajón	MDP	618	72	12	6
7	332893	Lateral esquerda	Left side	Lado izquierdo	MDP	2050	450	12	1
8	332894	Lateral direita	Right side	Lado derecho	MDP	2050	450	12	1
9	332895	Base gaveteiro	Drawer base	Base con cajones	MDP	1878	450	12	1
10	332896	Divisória esquerda	Left divider	divisor izquierdo	MDP	1373	402	12	1
11	332897	Painel espelho esquerdo	Left mirror panel	Panel izquierdo del retrovisor	MDP	1373	150	12	1
12	332898	Divisória direita	Right divider	divisor derecho	MDP	1373	402	12	1
13	332899	Prateleira	Shelf	Estante	MDP	618	312	12	2
14	332900	Chapéu	Hat	Sombrero	MDP	1878	450	12	1
15	332901	Painel espelho direito	Right mirror panel	Panel derecho del retrovisor	MDP	1373	150	12	1
16	332902	Prateleira nicho	Niche shelf	Estante nicho	MDP	350	140	12	6
17	332903	Vista superior	Upper view	Vista superior	MDP	1902	72	15	1
18	332904	Vista lateral	Side view	Vista lateral	MDP	2050	72	15	2
19	332905	Fundo inferior	Bottom fund	Fondo inferior	HDF	1898	273	3	2
20	332906	Fundo superior	Top fund	Fondo superior	HDF	1389	317	3	4
21	332907	Frente de gaveta	Drawer front	Frente del cajón	MDP	626	230	15	6
22	332908	Lateral de gaveta	Drawer side	Lado del cajón	MDP	350	120	12	12
23	332909	Contra fundo	Against background	Contra el fondo	MDP	569	110	12	6
24	332910	Fundo da gaveta	Drawer bottom	Fondo del cajón	HDF	591	355	3	6
25	332911	Apoio de gaveta	Drawer support	Soporte para cajón	MDP	350	72	12	6
26	332912	Porta de correr	Sliding door	Puerta corredera	MDP	1353	638	15	2

## INSTRUÇÃO MONTAGEM PRODUTO

Intructions to Assembly / Instrucciones de montaje

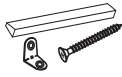

Separe as peças e acessórios de maneira organizada  
Separate parts and accessories in way organized  
Separe las piezas y accesorios de manera organizada

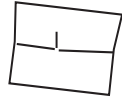

Forrar o chão com o papelão das embalagens.  
Cover the floor with the cardboard  
Cubra el suelo con la embalaje de cartón



É necessário 01 pessoa para montar o produto  
01 people are required to assemble the product  
Se requieren 01 persona para ensamblar el producto

O produto deve ser a montado por um profissional qualificado  
The product must be assembly by a professional  
El producto debe ser ensamblado por un profesional calificado

Ferramentas necessárias  
(não fornecidas)

Not include tools / No herramientas



## CUIDADO PARA CONSERVAÇÃO E LIMPEZA DO MÓVEL

Care to conservation and clean / Cuidados de limpieza

Peso máximo de carga informado refere-se a objetos distribuído de maneira uniforme sobre toda área de contato da peça



The maximum load weight informed refers to objects distributed evenly over the entire contact area of the part  
Conjunto de carga máxima de peso se refere a objetos distribuídos uniformemente sobre toda el área de contacto de la pieza de trabajo.



Não molhar o móvel e não expor em lugar úmido  
Do not wet the mobile and do not expose in a wet place  
No moje el producto y no exponer en un lugar húmedo



Não expor o móvel próximo de fontes de calor.  
Do not expose the mobile near heat sources  
no exponga cercano de fuentes de calor



Não usar produtos abrasivos.  
Do not use abrasive products.  
No utilice productos abrasivos.



Limpe com flanela limpa e seca.  
Clean with dry cloth  
Limpieza con un paño limpio y seco



Para limpar os carimbos das peças utilize uma borracha escolar ( item não fornecido)

Para clean the stamps on the pieces use a school eraser ( item not provided)

Para limpiar los sellos de las piezas utilice un borrador escolar ( artículo não incluido )

## LISTA DE ACESSÓRIOS E FERRAGENS / ACCESSORIES AND HARDWARE / ACCESORIOS Y HARDWARE



A- 700542-Cavilha 6x30 (48x)  
peg / cerrojo



B- 700543-Cavilha 6x60 (12x)  
peg / cerrojo



C - 700137-Parafuso 4,5x45 (50x)  
screw / tornillo



D- 700124-Parafuso 3,5x25 (42x)  
screw / tornillo

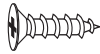

E- 700121-Parafuso 3,5x12 (267x)  
screw / tornillo



F - 700539-Cantoneira metálica  
4 furos 45x45x18mm (23x)  
corner / esquina



G- 700446-Porca cilíndrica (08x)  
Cylindrical Nut /  
Tuerca cilíndrica



H- 700146 - Parafuso minifix (18x)  
Minifix screw / Tornillo minifix



I- 700148 -Tambor Minifix (18x)  
Minifix Drum / Tambor minifix



J- 700157-Prego (182x)  
nail / clavo



K-700438-Suporte cabide (02X)  
hook support / soporte gancho



L - 703747-Bastão Alumínio (01x)  
Coat Rack / Perchero



M- 700171-Puxador Mdf 250mm (02x)  
Handle / Manija



N- 700113-Corrediça (06x)  
runners / corredera



O - 700464 - Kit com 8 Pes (1x)  
foot / pie



P - 700433-Suporte angular (8x)  
Angled support / Soporte en ángulo



Q- 703750-Perfil H (01x)  
Frame / Perfil



R- 703749-Perfil H (02x)  
Frame / Perfil

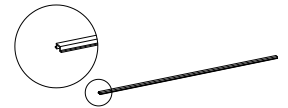

S - 703746 - Trilho superior (1x)  
top rail / carril superior

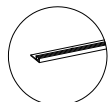

T - 703748 - Trilho inferior (1x)  
Bottom rail / Riel inferior

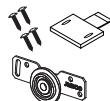

U - 703751 - Kit roldana (2x)  
Roller kit / Kit polea

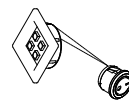

V - 700586 - Kit Luminária (1x)  
Luminaire kit/Kit de iluminación



W - 703744 - Espelho (1X)  
Mirror/Espejo



X- 700419 - Tapa furo minifix (38x)  
minifix cover / tapa minifix



Y- 700419 - Tapa furo minifix (24x)  
minifix cover / tapa minifix



Z - 700516 - Satche cola 20g (01x)  
Glue / Goma



AA- 700547-Junção (12x)  
junction / juncion

01º PASSO - Fazer a separação das corredeira

01º STEP - Separate the slides

01º PASO - Separar las diapositivas

N

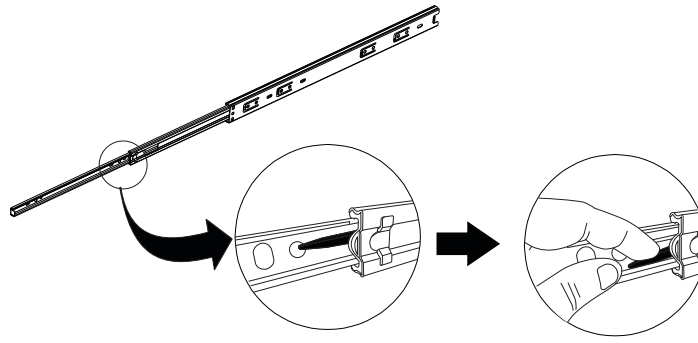

**Abaixe a alça preta e retire a peça conforme abaixo.  
Push the black pin down to remove the D1 part.  
Empujar para abajo la pieza negra para retirar la parte D1.**

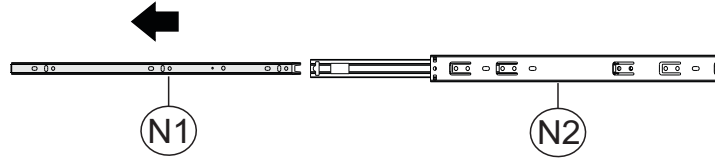

02º PASSO - Fixar os acessórios nas peças 5,7,8.

02º STEP - Fix the accessories to parts 5,7,8.

02º PASO - Fijar los accesorios a las piezas 5,7,8.

B



E



N2

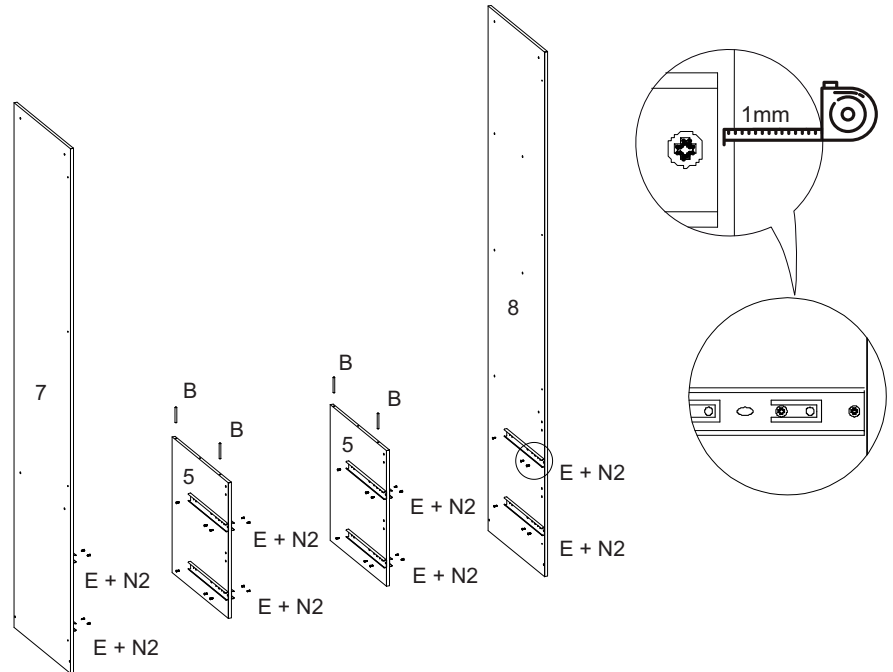
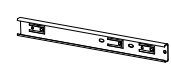

03º PASSO - Fixar o acessório na peça 14.

03º STEP - Fix the accessory to part 14.

03º PASO - Fijar el accesorio en la pieza 14.

S

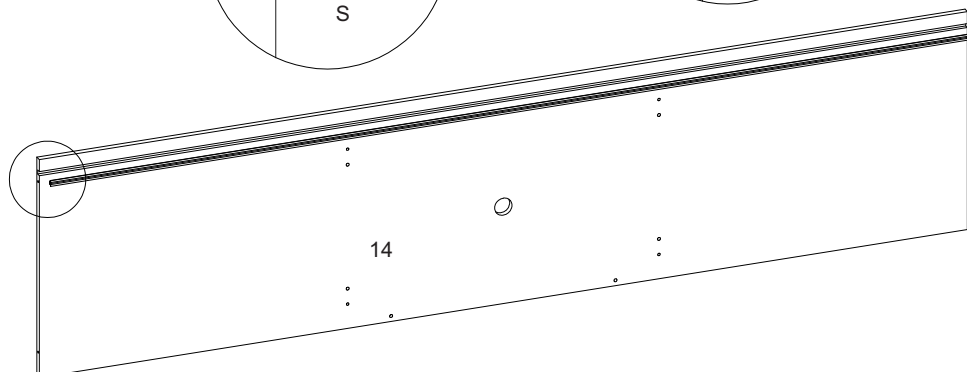
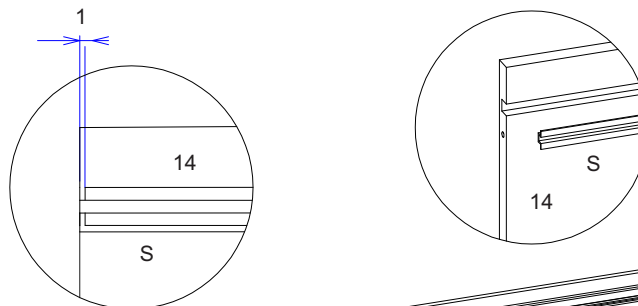

04° PASSO - Fixar os acessórios nas peças 26.

04° STEP - Fix the accessories to parts 26.

04° PASO - Fijar los accesorios en las piezas 26.

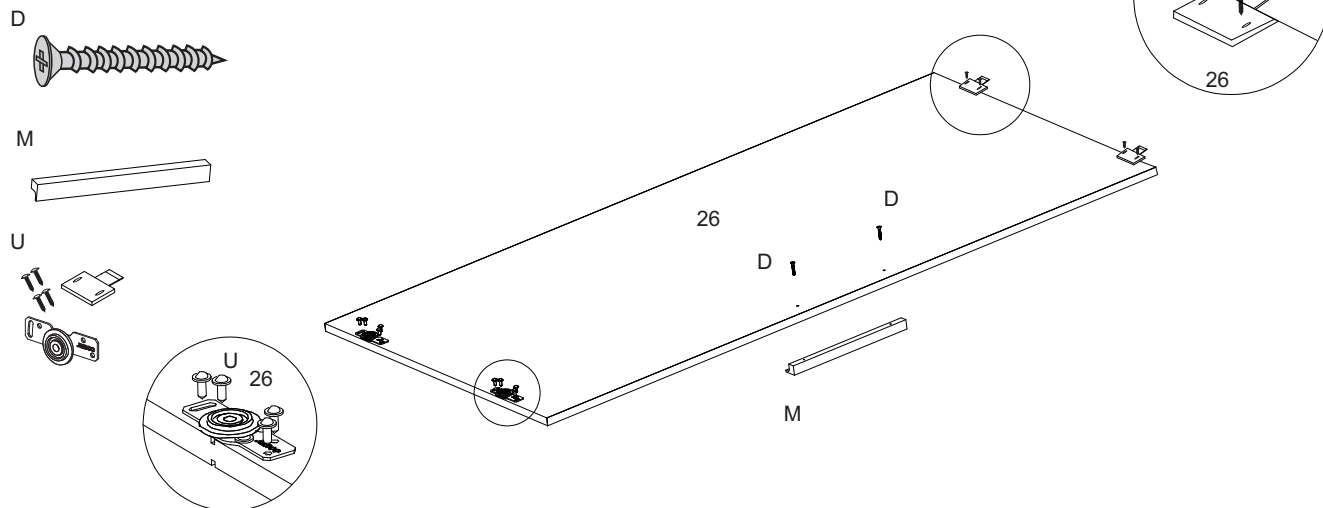

05° PASSO - Fixar os acessórios nas peças 6.

05° STEP - Fix the accessories to the parts 6.

05° PASO - Fijar los accesorios en las piezas 6.

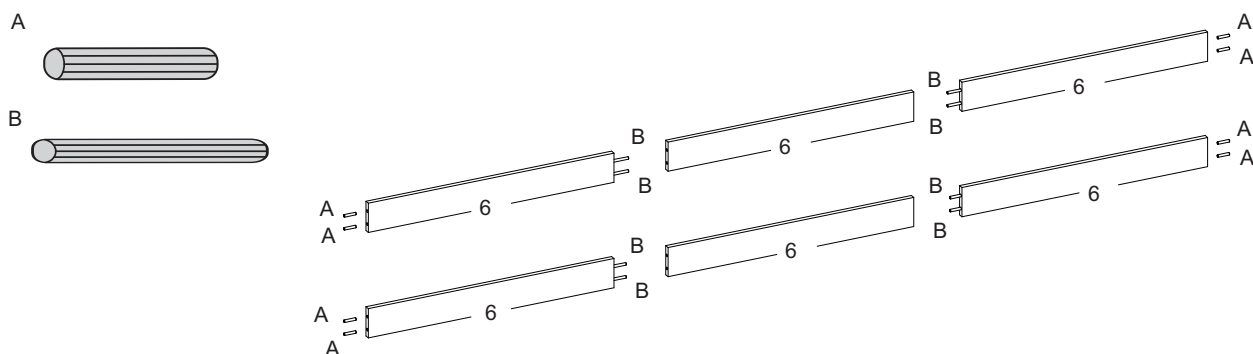

06° PASSO - Fixar a peça 3 nas peças 1 e 2.

06° STEP - Fix part 3 to parts 1 and 2.

06° PASO - Fijar la pieza 3 a las piezas 1 y 2.

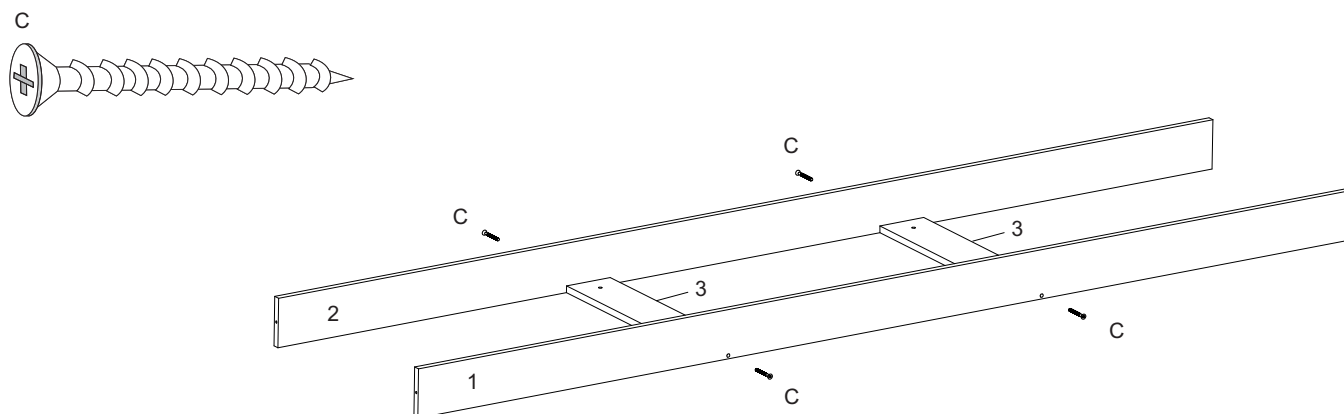

07° PASSO - Fixar o acessório O nas peças 1 e 2 e fixar peça 4 nas peça 1 e 2.

07° STEP - Fix accessory O to parts 1 and 2 and attach part 4 to parts 1 and 2.

07° PASO - Fijar el accesorio O a las piezas 1 y 2 y fije la pieza 4 a las piezas 1 y 2.

D



F



O

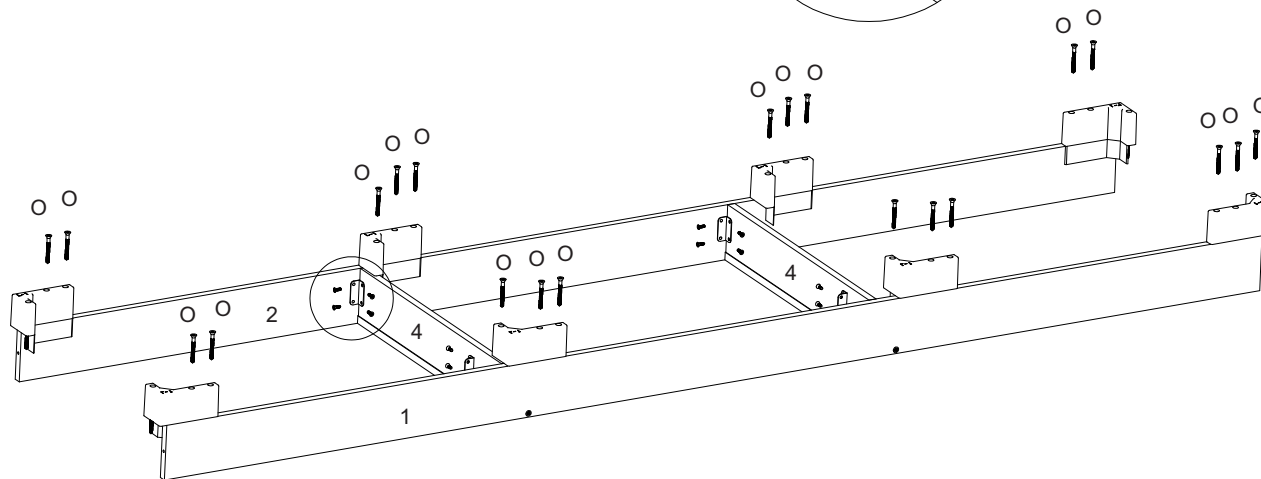
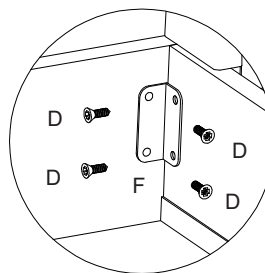

08° PASSO - Fixar peça 4 nas peças 5.

08° STEP - Fix part 4 to parts 5.

08° PASO - Fijar la pieza 4 a las piezas 5.

C

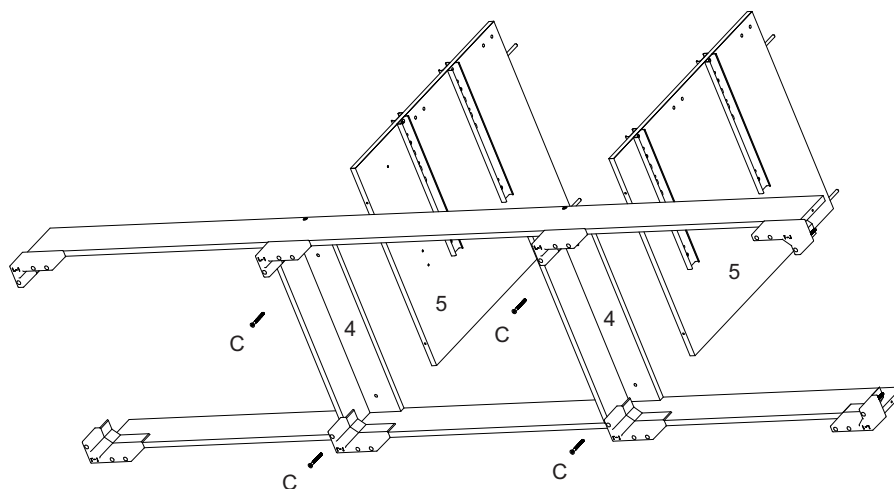
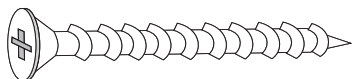

09° PASSO - Fixar peça 6 nas peças 5.

09° STEP - Fix part 6 to parts 5.

09° PASO - Fijar la pieza 6 a las piezas 5.

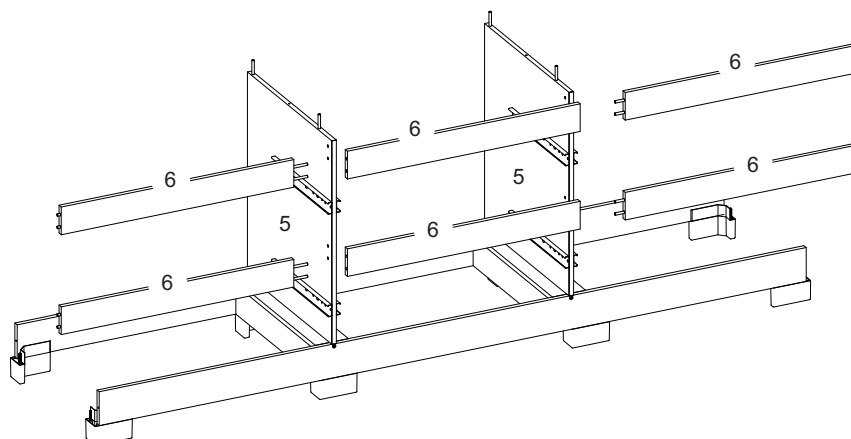

10° PASSO - Fixar as peças 7 e 8 nas peças 1,2,6.

10° STEP - Fix parts 7 and 8 to parts 1,2,6.

10° PASO - Fijar las piezas 7 y 8 en las piezas 1,2,6.

C

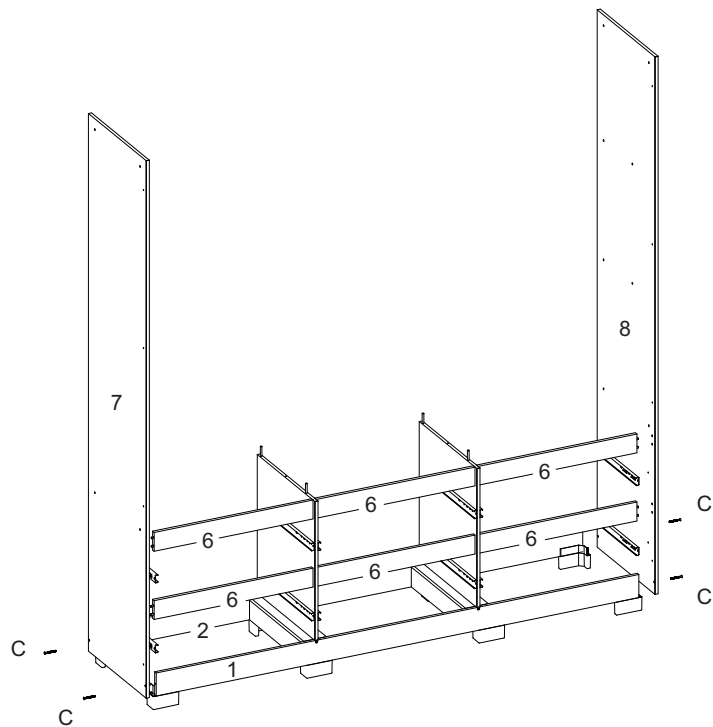
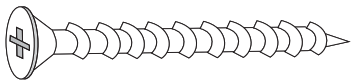

11° PASSO - Fixar o acessório D + F nas peças 6.

11° STEP - Fix accessory D + F to parts 6.

11° PASO - Fijar el accesorio D + F en las piezas 6.

D



F

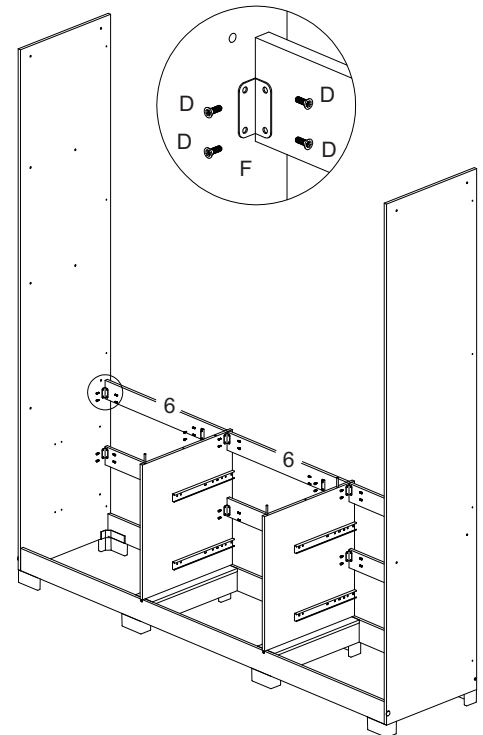

12° PASSO - Fixar peça 9 nas peças 5,7,8.

12° STEP - Fix part 9 to parts 5, 7, and 8.

12° PASO - Fijar la pieza 9 a las piezas 5, 7 y 8.

C

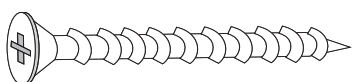

G

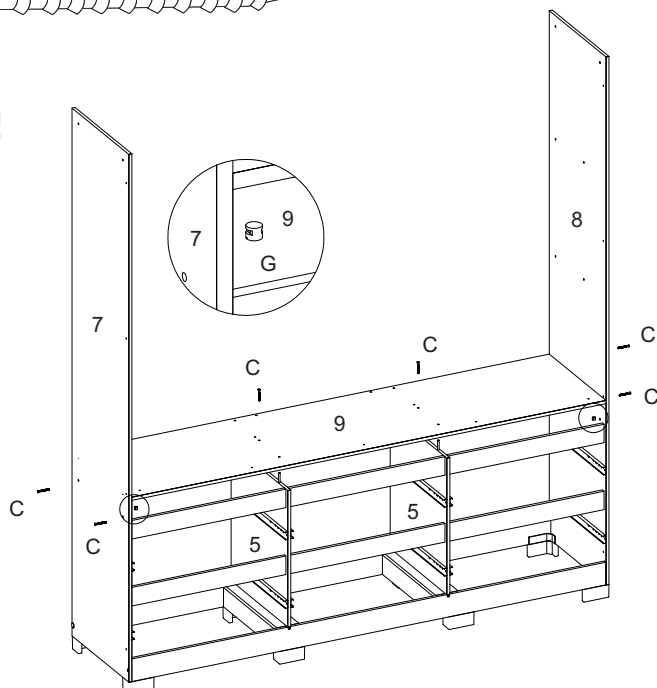

13° PASSO - Fixar peça 10 na peça 9.

13° STEP - Fix part 10 to part 9.

13° PASO - Fijar la pieza 10 a la pieza 9.

A



I



H

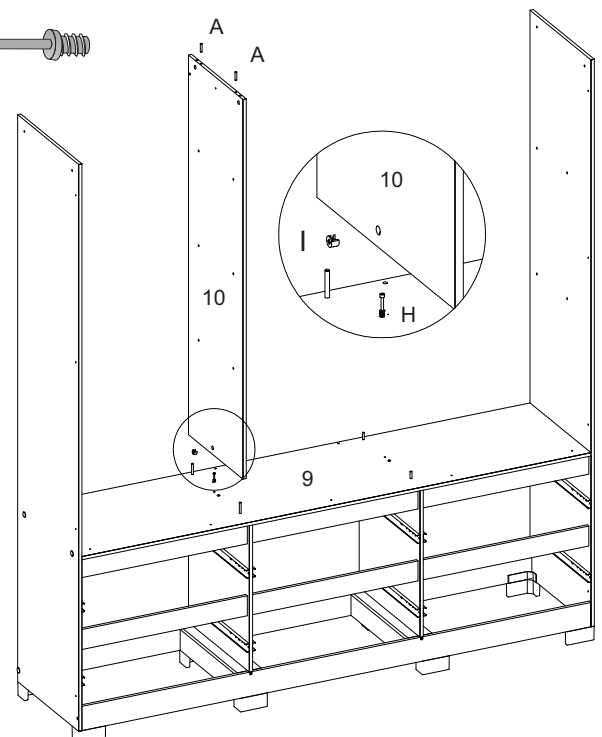

14° PASSO - Fixar peça 11 na peça 10.

14° STEP - Fix part 11 to part 10.

14° PASO - Fijar la pieza 11 a la pieza 10.

C

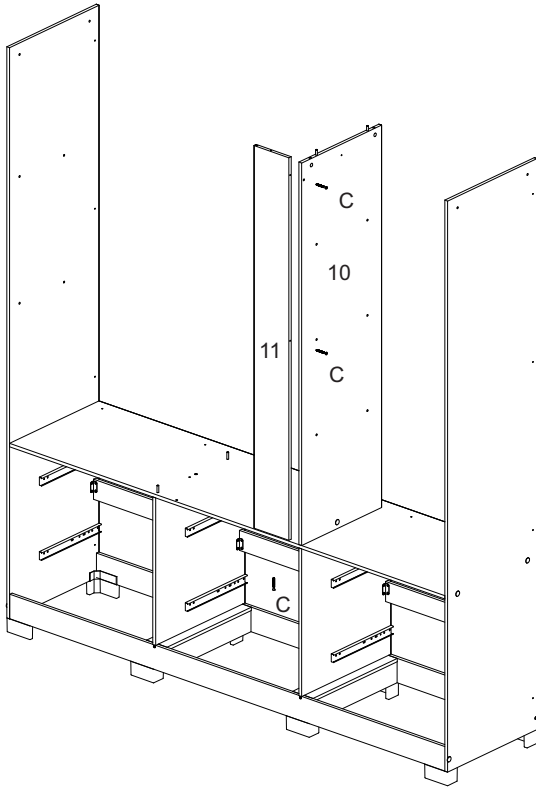
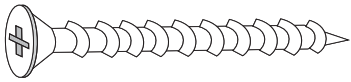

15° PASSO - Fixar peça 12 na peça 9.

15° STEP - Fix part 12 to part 9.

15° PASO - Fijar la pieza 12 a la pieza 9.

A



I



H

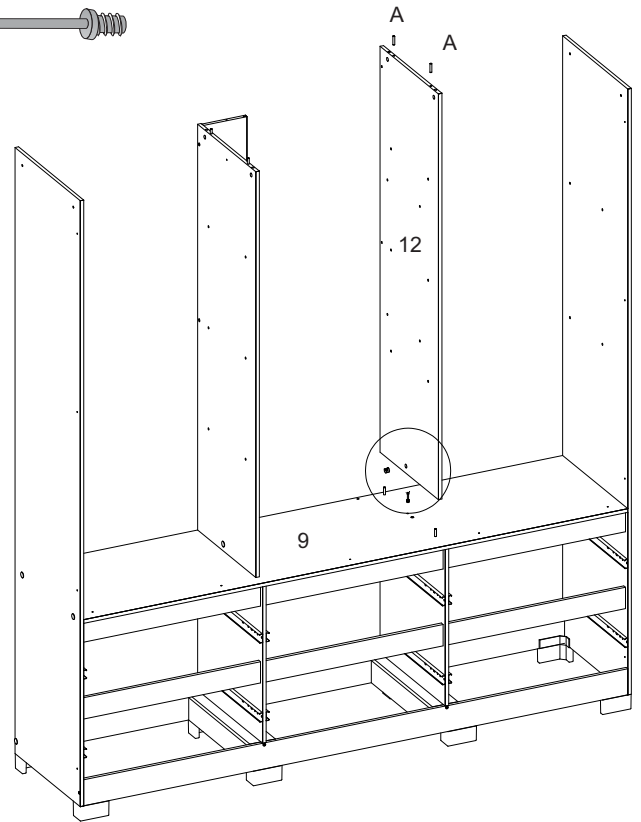
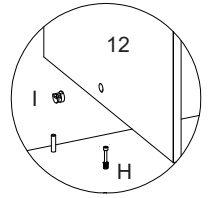

16° PASSO - Fixar peça 13 nas peças 8 e 12.

16° STEP - Fix part 13 to parts 8 and 12.

16° PASO - Fijar la pieza 13 a las piezas 8 y 12.

C

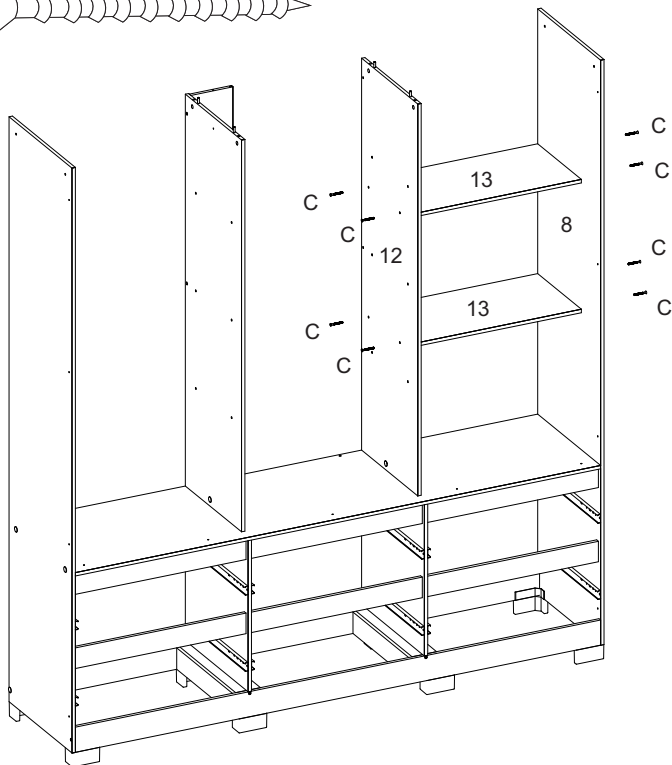
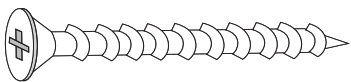

17° PASSO - Fixar peça 14 nas peças 7,8,10,12.

17° STEP - Fix part 13 to parts 8 and 12.

17° PASO - Fijar la pieza 13 a las piezas 8 y 12.

C

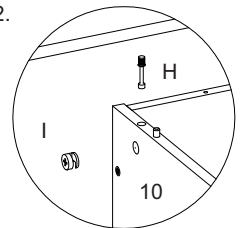
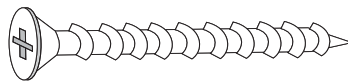

G



H



I

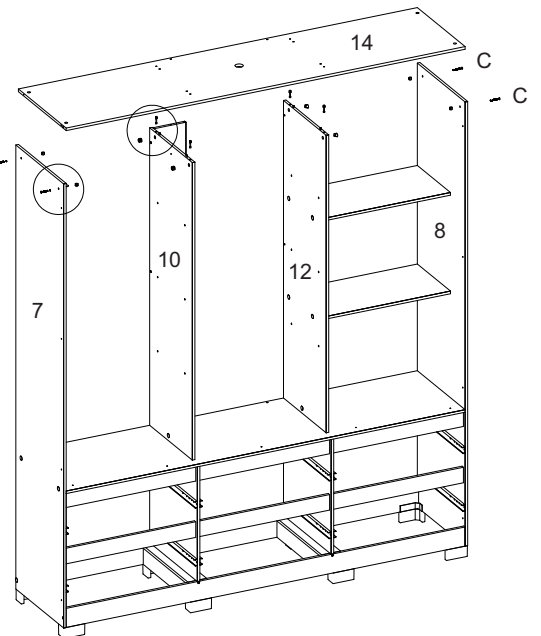
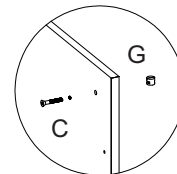

18° PASSO - Fixar peça 15 na peças 12 e fixar o acessório W.

18° STEP - Fix part 15 to parts 12 and attach accessory W.

18° PASO - Fijar la pieza 15 a las piezas 12 y fijar el accesorio W.

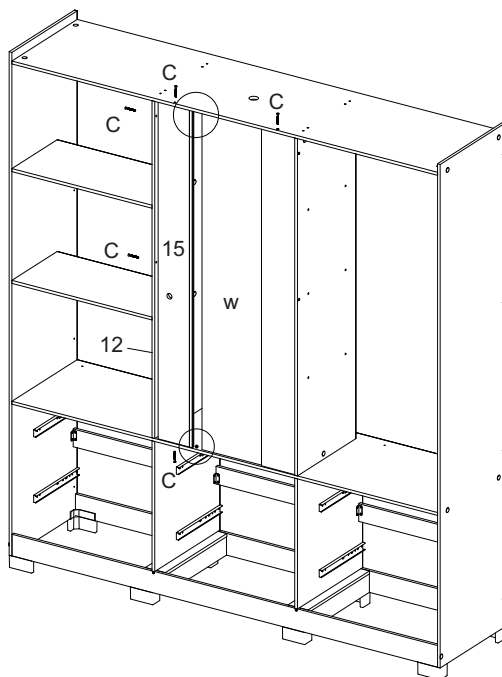
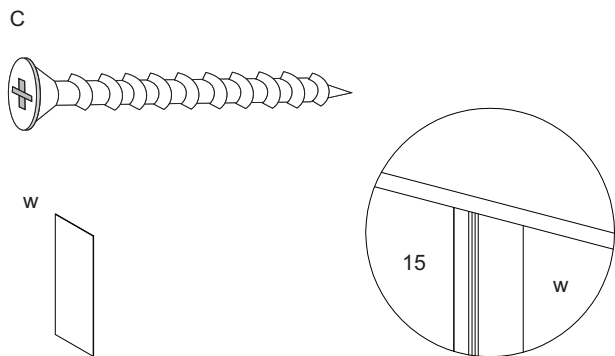

19° PASSO - Fixar peça 16 nas peças 10, 11, 12 e 15.

19° STEP - Fix part 16 to parts 10, 11, 12, and 15.

19° PASO - Fijar la pieza 16 a las piezas 10, 11, 12 y 15.

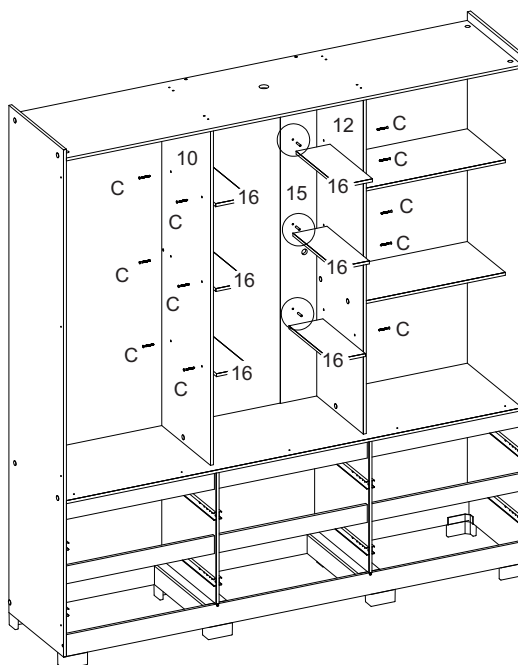
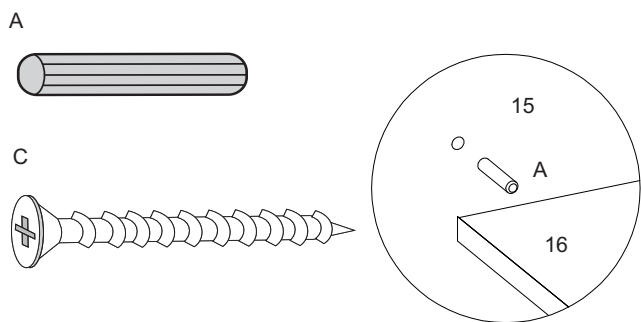

20° PASSO - Fixar o acessório v nas peças 14 e 15.

20° STEP - Fix accessory v to parts 14 and 15.

20° PASO - Fijar el accesorio v en las piezas 14 y 15.

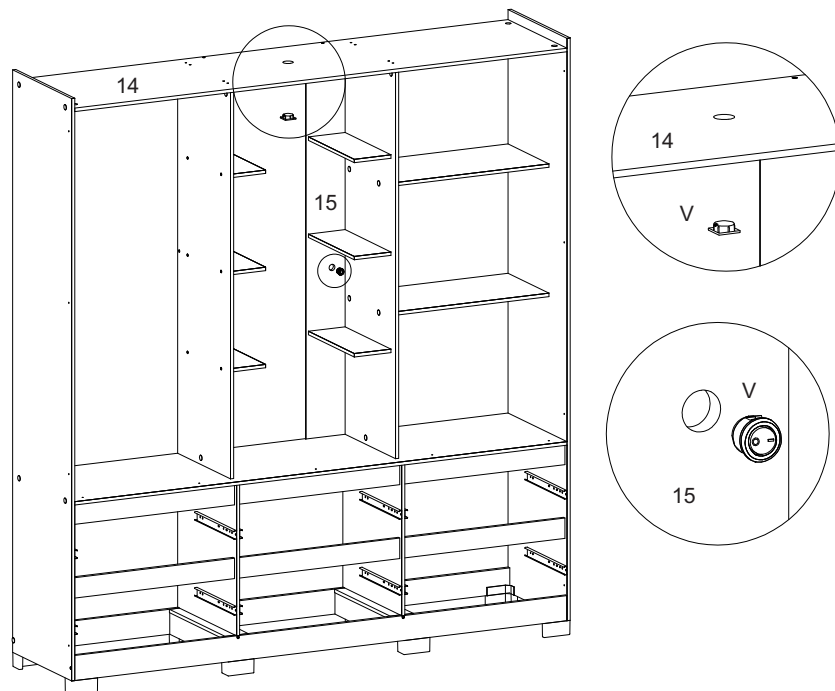
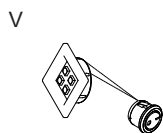



21° PASSO - Fixar os acessórios nas peça 17.

21° STEP - Fix the accessories to part 17.

21° PASO - Fijar los accesorios en la pieza 17.

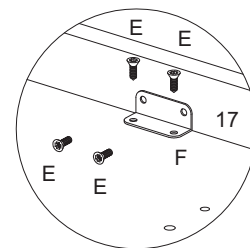
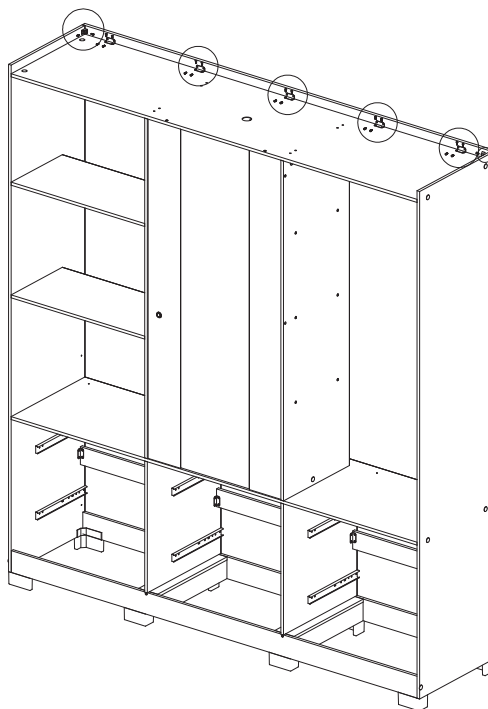
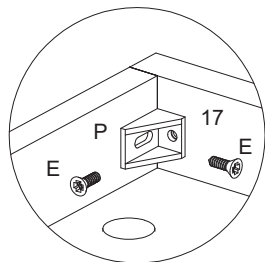
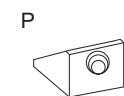

22° PASSO - Fixar os acessórios na peça 9.

22° STEP - Fix the accessories to part 9.

22° PASO - Fijar los accesorios en la pieza 9.

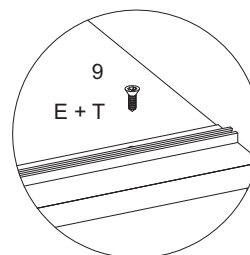
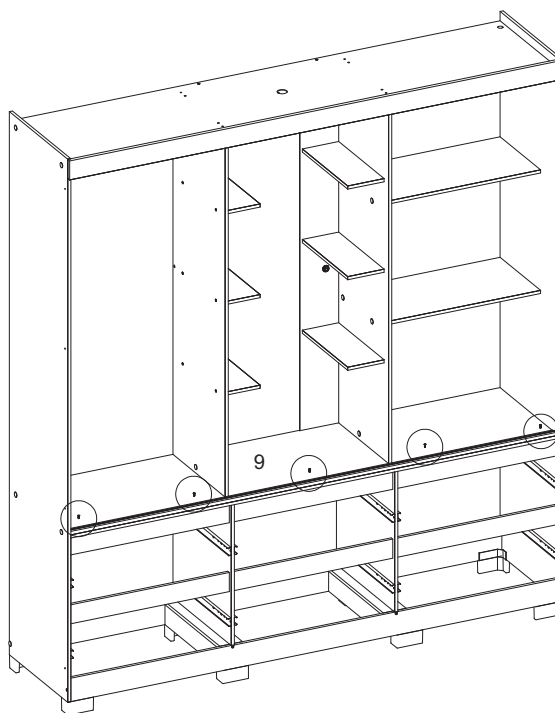
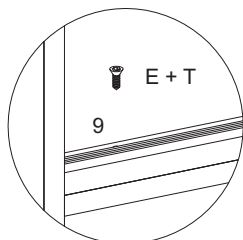
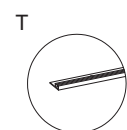

23° PASSO - Fixar peças 18 nas peças 7 e 8.

23° STEP - Fix parts 18 to parts 7 and 8.

23° PASO - Fijar las piezas 18 a las piezas 7 y 8.

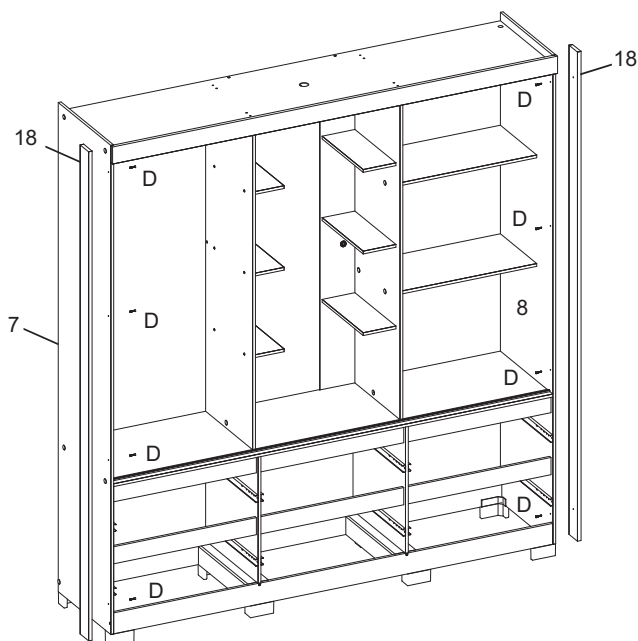
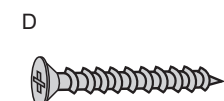

24° PASSO - Fixar as peças 19 e 20 atrás do produto.

24° STEP - Fix parts 19 and 20 to the back of the product.

24° PASO - Fijar las piezas 19 y 20 detrás del producto.

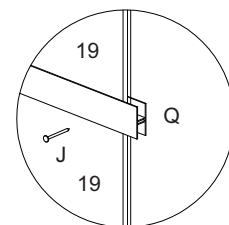
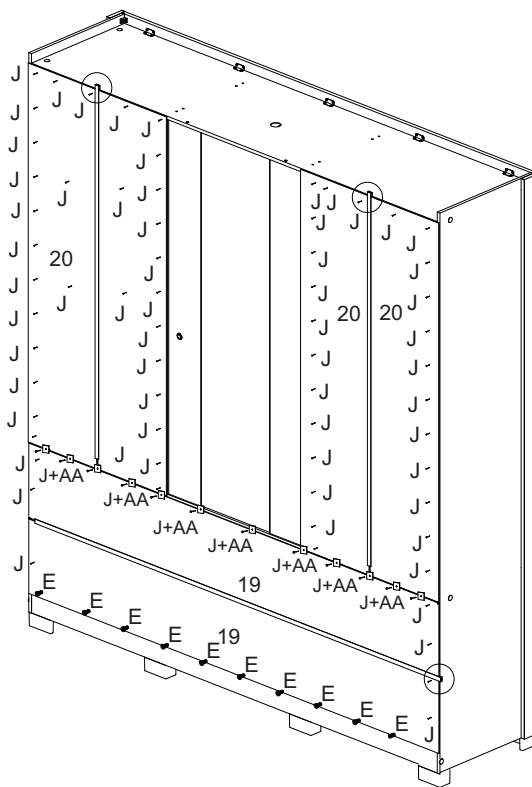
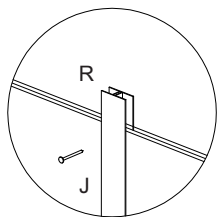
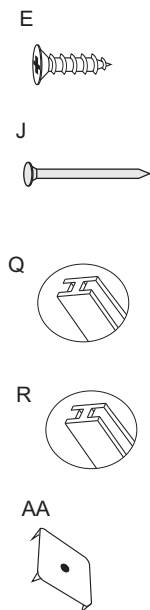

25° PASSO - Fixar o acessório na peça 7 e 10.

25° STEP - Fix the accessory to parts 7 and 10.

25° PASO - Fijar el accesorio en las piezas 7 y 10.

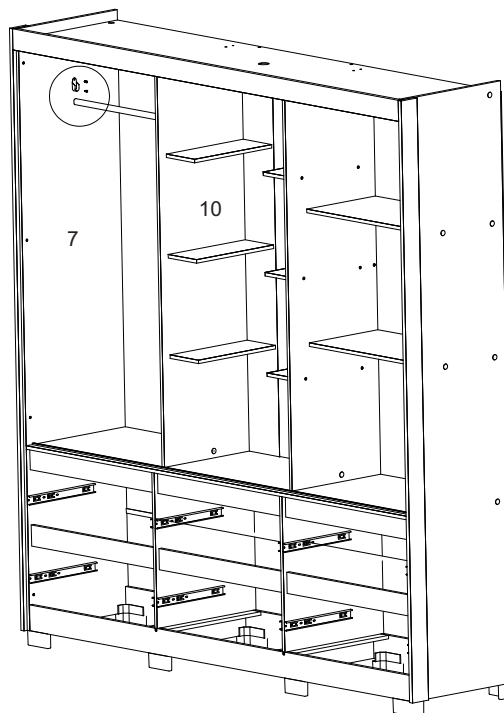
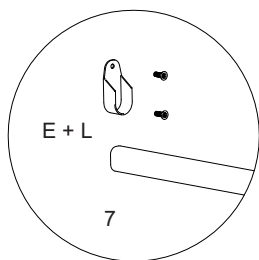
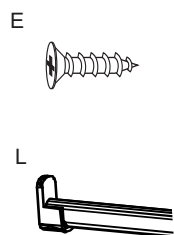

26° PASSO - Fixar peças 22 nas peças 21 e 23.

26° STEP - Fix parts 22 to parts 21 and 23.

26° PASO - Fijar las piezas 22 a las piezas 21 y 23.

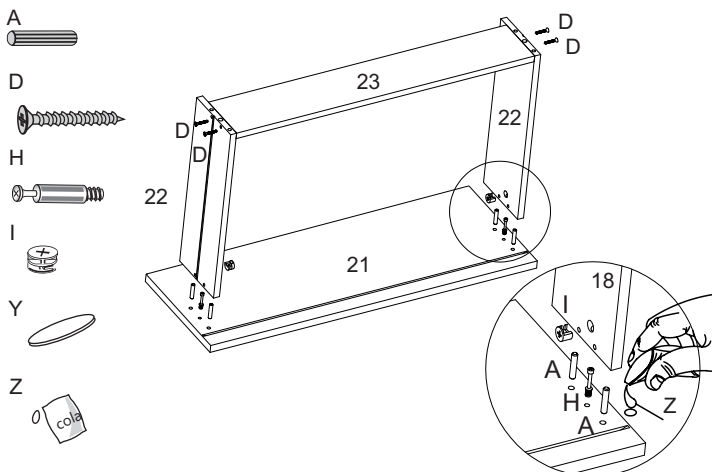

27° PASSO - Fixar peça 24 nas peças 22 e 23.

27° STEP - Fix part 24 to parts 22 and 23.

27° PASO - Fijar la pieza 24 a las piezas 22 y 23.

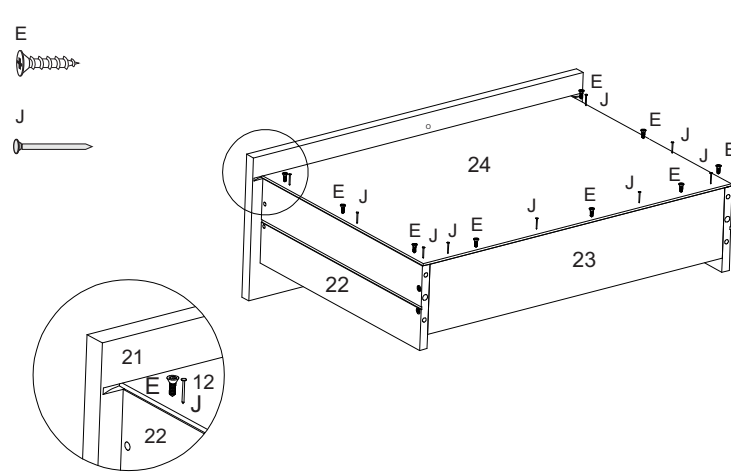

28° PASSO - Fixar a peça 25 nas peças 21 e 23.

28° STEP - Fix part 25 to parts 21 and 23.

28° PASO - Fijar la pieza 25 a las piezas 21 y 23.

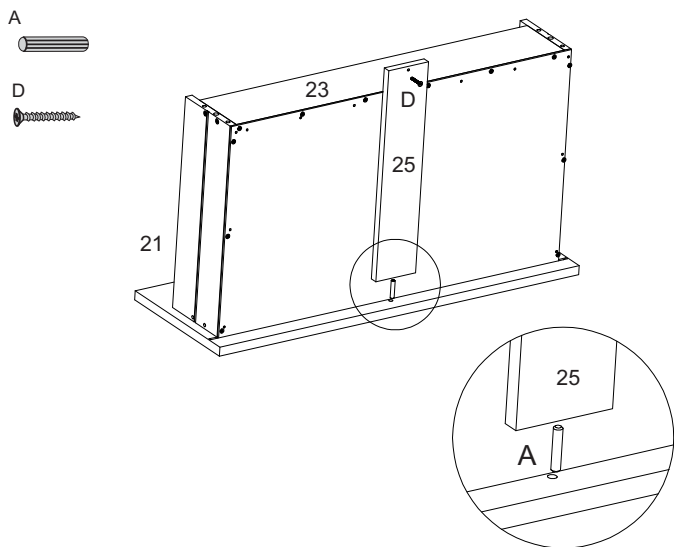

29° PASSO - Fixar os acessórios nas peças 21,22 e 25

29° STEP - Attach the accessories to parts 21, 22 and 25.

29° PASO - Fijar los accesorios en las piezas 21, 22 y 25.

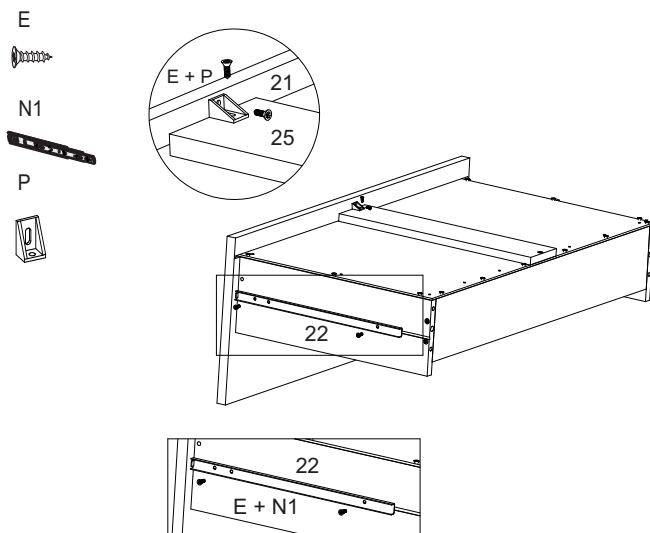

30° PASSO - Encaixar as portas no produto

30° STEP - Fitting the doors to the product

30° PASO - Fitting the doors to the product

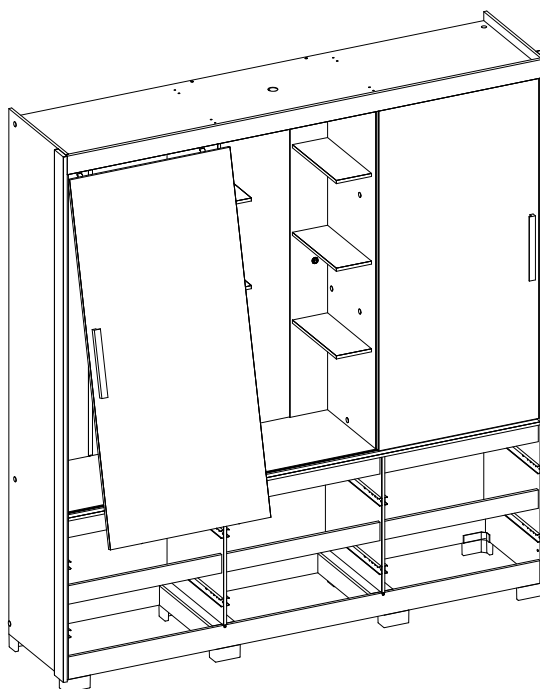

31° PASSO - Encaixar as gavetas no produto

31° STEP - Fitting the drawers to the product

31° PASO - Montaje de los cajones al producto.

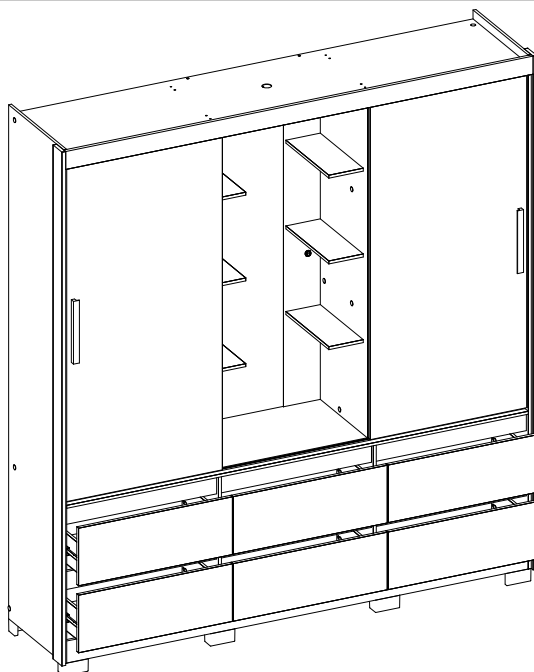
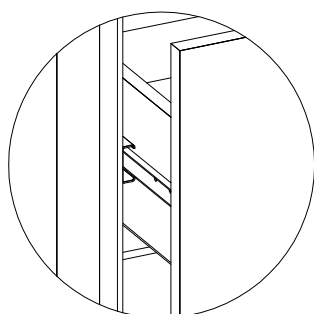

Aspecto final do produto

Final product aspect

Aspecto final del producto

